

STL-820

LED Interior Step Light

Catalog #		Type
Project		Date
Prepared by		

LED

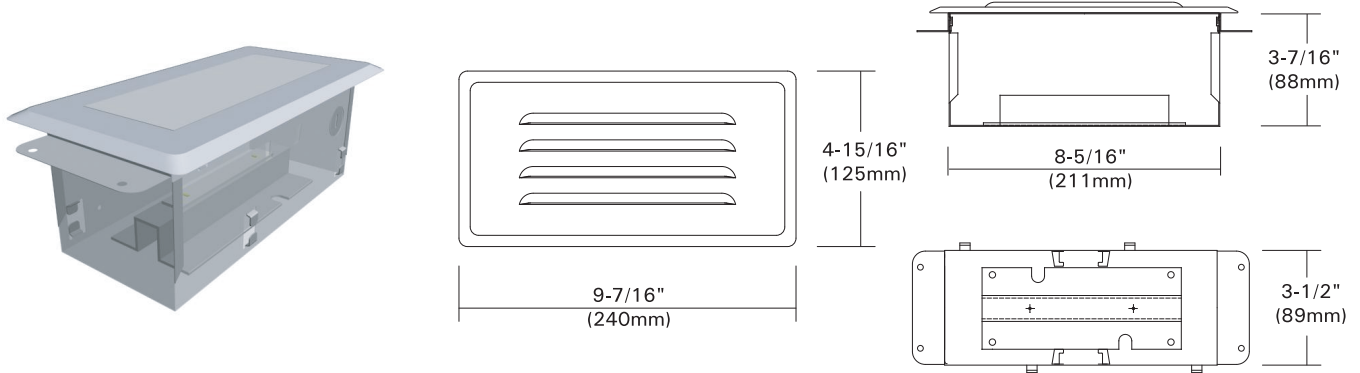

DESCRIPTION

The STL-820 is designed with LED lamp permanently installed in the fixture for easier, economical maintenance as of long lasting life of LED lamp.

DESIGN FEATURES

Illumination

- Illumination is accomplished with long lasting, high out-put Light Emitting Diodes (LEDs).

Housing & Trims

- Cast aluminum housing and trim painted in weather proof white & black or silver.

Electronics

- 120V AC input for operation of 1W X 4 LED chips (4W Max.)

Input Power Requirements

- AC only - Input 120V.

Code Compliance

- UL damp location listing on select units only.

Warranty

- 50,000hr of lamp life.

Listing cCSA-us Certificated

TRIM



Louvered face plate

TM-811-WH
TM-811-BK
TM-811-SI



Open face plate

TM-812-WH
TM-812-BK
TM-812-SI

ORDERING INFORMATION

Cat.#	Trims	Finish	Option
STL-820	- TM-811 : Louvered - TM-812 : Open	- WH : White - BK : Black - SI : Silver	- HB : 24" Hanger Bars

Example : STL-820 + TM-811-WH